

Prefabricated Aluminium Scaffolding Manufacturers' Association Ltd.

Trading as
PASMA and
Prefabricated Access Suppliers' and Manufacturers' Association

SECRETARY
P.O. Box, 1828, West Mersea, ESSEX. C05 8HY Tel & Fax: 01206 382666

MANUFACTURING MEMBERS

COMPANY	ADDRESS	PRODUCT
Aliscaff Limited* Tel: 020 8808 5005 Fax: 020 8801 9851	Unit 2, Hotspur Industrial Estate, West Road, Tottenham London N17 0XJ	ALISCAFF
SGB Branch Operations* Tel: 01403 791417 Fax: 01403 790881	Stane Street Slinfold, Horsham, West Sussex RH13 7RD	BOSS
Turner Access Limited* Tel: 0141-309 5555 Fax: 0141-309 5436	65 Craigtoun Road, Glasgow G51 3EQ	TRADESMAN
SGB Youngman* (Incorporating Access International) Tel: 01403 791417 Fax: 01403 790881 and at Tel: 01621 745996 Fax: 01621 850219	Stane Street Slinfold, Horsham West Sussex RH13 7RD The Causeway Maldon, Essex CM9 4LJ	BOSS CLIMALLOY HI-WAY ZIG-ZAG EASI-BUILD
Plettac NSG Plc* Tel: 01244 289166 Fax: 01244 280432	Parkway Deeside Industrial Park Deeside, Flintshire CH5 2NS	EIGERTOWER EIGERDECK
Upright Tel: (01) 2024100 Fax: (01) 2024102	Pottery Road Dun Laoire Ireland	INSTANT ZIP-UP SPANDEK
Euro Towers Ltd* Tel: 01604-644774 Fax: 01604-499544	Unit 5, Edgemoad Close Round Spinney Northampton NN3 8RG	KLIK LADDER FRAME

*PASMA Registered Training Centres

Applications are invited for membership from qualifying companies and should be addressed to the P.A.S.M.A. secretary above.

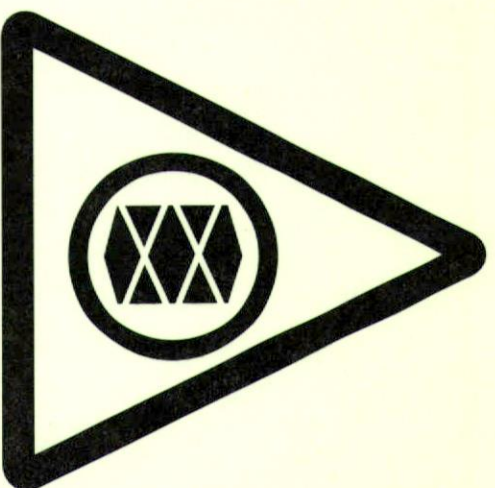

OPERATOR'S CODE OF PRACTICE

PASMA

Prefabricated Access Suppliers' & Manufacturers' Association

NEW EDITION PUBLISHED JUNE 2000
(7th Revision)

Applies only to Prefabricated Towers, manufactured in aluminium alloy or fibreglass, approved to BS 1139 Part 3 1994 (HD 1004) and which carry a current British Standard or other equivalent mark of approval

£5.00

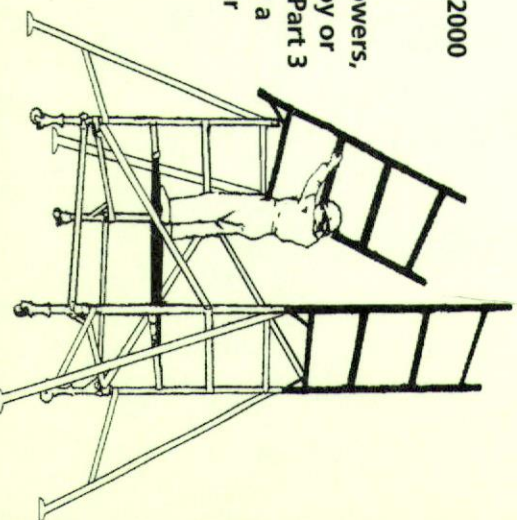

ITEM No: 2000-009

PASMA REGISTERED TRAINING CENTRES

CONTENTS

- *Aliscaff Limited**
Unit 2, Hotspur Industrial Estate,
West Road, Tottenham
London N17 0XJ
Tel: 020 8808 5005
Fax: 020 8801 9851
- *Cape Hire & Sales**
Cape Industrial Services,
Docks Road, The Docks
Port Talbot
West Glamorgan SA13 1RE
Tel: 01639 883285
Fax: 01639 883816
- *Eveready Equipment Hire Ltd.**
Unit 1,
The Arches Business Centre
Merrick Road
Southall
Middlesex UB2 4AU
Tel: 020 8843 1200
Fax: 020 8571 3319
- *Euro Towers Ltd.**
Unit 5, Edgemoad Close,
Round Spinney,
Northampton NN3 8RG
Tel: 01639 883285
Fax: 01639 883816
- *Hi-Point Scaffolding Ltd.**
Unit 3, Roman Ridge Road
Roman Ridge Industrial Estate
Sheffield S9 1GB
Tel: 01604 644774
Fax: 01604 499544
- *HSS Hire Service Group plc**
25 Willows Lane, Mitcham
Surrey, CR4 4TS
Tel: 020 8260 3100
Fax: 020 8687 5005
- *Initial Deborah Services**
10 South Parade, Wakefield
West Yorkshire WF1 1LS
Tel: 01924 378222
Fax: 01924 366250
- *Lawson's Training Centre Ltd**
Whinbank Farm, Distington,
Workington, Cumbria CA14 4QH
Tel: 01946 833313
- *Lodge Scaffold Ltd.**
Crows Nest
Ashton Road
Billinge, Wigan
Lancashire WN5 7XY
Tel: 01744 891717
Fax: 01744 891718
- *M&S Hire Ltd.**
Unit 11c Dolphin Park
Cremers Road, Eurolink
Sittingbourne, Kent ME10 3HB
Tel: 01795 429731
Fax: 01795 427790
- *Martin Plant Hire Ltd**
Kensington House,
227 Sauchiehall Street
Glasgow G2 3EX
Tel: 0141 332 5197
Fax: 0141 332 6875
- *Planet Platforms**
146a Wakefield Road
Ossett, Wakefield WF5 9AH
Tel: 01924 263377
Fax: 01924 267090
- *Plettac NSG Plc**
Parkway,
Deeside Industrial Park
Deeside, Flintshire CH5 2NS
Tel: 01244 289166
Fax: 01244 280432
- *Rapid Hire (UK) Ltd.**
Intersection House,
110 Birmingham Road,
West Bromwich B70 6RX
Tel: 0121 500 0700
Fax: 0121 500 5253
- *SGB Branch Operations**
Stane Street,
Slinfold, Horsham,
West Sussex RH13 7RD
Tel: 01403 791417
Fax: 01403 790881
- *Speedy Hire (Southern) Ltd.**
57 Cowley Road,
Cambridge CB4 4DN
Tel: 01284 829829
Fax: 01284 829828
- *SGB Youngman**
(Incorporating Access International)
Stane Street, Slinfold,
Horsham, West Sussex RH13 7RD
Tel: 01403 791417
Fax: 01403 790881
The Causeway,
Maldon, Essex CM9 4LJ
Tel: 01621 745996
Fax: 01621 850219
- *Turner Access Limited**
65 Craighon Road,
Glasgow G51 3EQ
Tel: 0141 309 5555
Fax: 0141 309 5436
- *Upright**
Pottery Road,
Dun Laogair, Ireland
Tel: (01) 2024100
Fax: (01) 2024102
- *1X Hire Ltd.**
Manor House, Ipswich Road
Cardiff
South Glamorgan CF3 7AQ
Tel: 029 2048 7487

	Page		Page
1. Introduction	1	6. Safe Use of Towers	12
2. Scope of Practice	1	Guardrails & Toeboards	12
3. Tower Components	2	Platforms	12
Three typical types of Prefabricated Aluminium Alloy Towers	3	Safe Loading	12
4. Erection and Dismantling Instruction Manual	4	Incomplete Towers	12
Type & Number of Components	4	Moving Towers	13
Castors, Baseplates & Adjustable Legs	4	Cantilever Platforms	14
Base Sections	5	Use of Scaffold Boards & Staging	14
Upper Sections	5	7. Hazards	15
Braces	5	Safety Check List	15
Platforms	5	Safety Check List (Cont.)	16
Guardrails & Toeboards	6	8. Inspection	17
Scaffold Couplers	6	Before Erection of Tower	17
Means of Access	6	Before use of Tower	17
Rest Platforms	7	Before use of Tower (Cont.)	18
		During use of Tower	18
		9. Care & Maintenance	19
		Handling, Transport, Storage	19
		10. Regulations, Standards & Recommendations	20
5. Stability of Towers	7	11. Training	21
Tower with Stabilisers	7	12. Hirer/Dealer and Training Members	22
Tower with Outriggers	7	13. Registered Training Centres	23
Height Calculations	8	14. Manufacturing Members	Back
Wind	8	Cover	Cover
Wind Loads on Tower	8		
Other Horizontal Loads	8		
Vertical Eccentric Loads	9		
Outriggers & Stabilisers	9		
Sheeted Towers	9		
Tying In	9		
Use as Facade Scaffold	9		
Tie Arrangements	10		
Use of Tube & Couplers	11		
Ballast weights, Guy-ropes & Towers in Public Places	11		

1. INTRODUCTION

P.A.S.M.A. is an association consisting of full members who manufacture Mobile Access Towers (MATs) and who are licenced to manufacture MATs to BS 1139 Part 3 1994 (HD1004), and which carry the current British Standard Kitemark or other equivalent mark of approval (e.g. Testguard, GS Mark etc.). Other organisations associated with the MAT market who are admitted as Associate Members have a requirement of their membership that the bulk of any MATs that they use should also carry the current British Standard Kitemark or equivalent mark of approval.

The UK Statutory Instrument which applies to MATS is the Construction (Health Safety and Welfare) Regulations 1996, which revokes the Construction (Working Places) Regulations 1996. Tower Scaffold Guidance note GS42 has now been withdrawn.

This seventh edition of the PASMA Code of Practice has been written to particularly take account of the latest British/European Standard requirements, and it will supersede all previous editions and continue to provide guidance on safety.

2. SCOPE OF THIS CODE OF PRACTICE

This PASMA Code of Practice mainly relates to free-standing access towers manufactured from prefabricated components where the principal structural materials are aluminium alloys or fibreglass and specifically relates to towers that have a British Standard or equivalent U.K. or European approval mark.

This type of prefabricated aluminium alloy tower system can also be assembled to form continuous facade scaffolds and special structures, such as portal frames, bridges etc, but these special structures are outside the scope of this Code of Practice and users must consult their supplier for further information.

The scope of BS 1139 Part 3 1994 (HD1004) is limited to standard mobile prefabricated towers of height from 2.5m to 12m (indoors) and from 2.5m to 8m (outdoors)

This PASMA document is a code of practice and should be used in conjunction with the appropriate manufacturers instruction manuals. Their instructions are written in conformity with BS EN 1298, which is the British/European standard covering the rules and guidelines for the preparation of instruction manuals for aluminium towers.

HIRER/DEALER & TRAINING MEMBERS

Easy Access Ltd.

Crag Crescent, Clondalkin
Industrial Estate, Dublin 22
Ireland
Tel: 00353 (01) 450 5646
Fax: 00353 (01) 467 0448

*Eveready Equipment Hire Ltd.

Unit 1,
The Arches Business Centre
Merrick Road
Southall
Middlesex UB2 4AU
Tel: 020 8843 1200
Fax: 020 8571 3319

Generation Access Ltd.

Unit 8,
Horton Road Industrial Estate
Off Horton Road
West Drayton
Middlesex UB7 8UL
Tel: 01895 430630
Fax: 01895 430434

Go Hire Access

Unit 1, Safety House
Kerfoot Street
Warrington
Cheshire WA2 8NU
Tel: 01925 444949
Fax: 01925 444696

Hewden Hire Centres Ltd.

Trafford House
Chester Road, Stretford
Manchester M32 0RL
Tel: 0161 848 8621
Fax: 0161 872 9737

*Hi-Point Scaffolding Ltd.

Unit 3, Roman Ridge Road
Roman Ridge Industrial Estate
Sheffield S9 1GB
Tel: 0114 261 0202
Fax: 0114 256 1154

*HSS Hire Service Group plc

25 Willows Lane, Mitcham
Surrey, CR4 4TS
Tel: 020 8260 3100
Fax: 020 8687 5005

*Initial Deborah Services

10 South Parade, Wakefield
West Yorkshire WF1 1LS
Tel: 01924 378222
Fax: 01924 366250

*Lawson's Training Centre Ltd

Whinbank Farm, Distington,
Workington, Cumbria CA14 4QH
Tel: 01946 833313

*Lodge Scaffold Ltd.

Crows Nest
Ashton Road
Billinge, Wigan
Lancashire WN5 7XY
Tel: 01744 891717
Fax: 01744 891718

Lord Hire Centres

337/343 Shields Road
Byker Hill Industrial Area
Newcastle upon Tyne NE6 2UD
Tel: 0191 2653880
Fax: 0191 2762566

*M&S Hire Ltd.

Unit 11c Dolphin Park
Cremers Road, Eurolink
Sittingbourne, Kent ME10 3HB
Tel: 01795 429731
Fax: 01795 427190

*Martin Plant Hire Ltd

Kensington House,
227 Sauchiehall Street
Glasgow G2 3EX
Tel: 0141 332 5197
Fax: 0141 332 6875

*Planet Platforms

146a Wakefield Road
Ossett, Wakefield WF5 9AH
Tel: 01924 263377
Fax: 01924 267090

*Rapid Hire (UK) Ltd.

Intersection House,
110 Birmingham Road,
West Bromwich B70 6RX
Tel: 0121 500 0700
Fax: 0121 500 52533

*Speedy Hire (Southern) Ltd.

57 Cowley Road,
Cambridge CB4 4DN
Tel: 01284 829829
Fax: 01284 829828

Universal Access & Power Plant

14 Ponsy Road
Horspath Road Industrial Estate
Cowley, Oxford OX4 2RD
Tel: 01865 450000
Fax: 01865 451111

*TX Hire Ltd.

Manor House, Ipswich Road
Cardiff
South Glamorgan CF3 7AQ
Tel: 029 2048 7487

11 TRAINING

The Construction (Health, Safety & Welfare) Regulations 1996, require that the installation or erection of Mobile Aluminium Towers (MATs) should be carried out under the supervision of a competent person. A competent person is considered to be a person possessing such training, technical knowledge or experience as may be appropriate having regard to the nature of the activity. PASMA therefore sponsors a training course operated by certain authorised member companies.

The course is based on a format and content agreed by all PASMA members influenced by their own extensive experience. Hence it has great value as a training programme, and is widely recognised by safety professionals.

A PASMA A4 size Competency Certificate and a credit card sized ID Card with encapsulated photograph is issued to successful delegates who pass the written and practical test. The rear of the ID card is endorsed as follows:- This is to certify that the person named overleaf is now considered "competent" in that he meets the requirements of "training", as required by section 28 of the Construction (Health, Safety & Welfare) Regulations 1996, and is considered to be competent in the following areas relating to Mobile Access Towers (MATs) manufactured by PASMA full member companies.

1. The assembly of MATs
2. The use of MATs
3. The repositioning of MATs
4. The disassembly of MATs
5. The Supervision of others involved in 1-4
6. The Inspection and reporting on MATs as required by section 29 of the Construction (Health, Safety & Welfare) Regs. 1996.

Further details can be obtained from any PASMA member.

PASMA Training Courses are only available from approved PASMA members (full or associate), they are not available from any other source. **Please be aware that so called "PASMA Type" courses offered by non approved companies are not authorised by PASMA and their standards are not subject to the PASMA stringent auditing procedures used to continually monitor the PASMA Approved Training Centres, the Instructor, course contents, and the written and practical examination criteria.**

Whilst individual PASMA Training Courses use one particular make of MAT, it is considered that a successful candidate would be equally competent as above in respect of any other PASMA manufacturer's MAT, provided he was in possession of the appropriate manufacturer's IM.

The course is designed to instruct a maximum of 12 delegates per course and arrangements can usually be made to consolidate delegates from different companies to minimise cost.

IF IN DOUBT - ASK YOUR SUPPLIER

3. TOWER COMPONENTS

3.1 The main structure comprises frames, diagonals and horizontal braces, adjustable legs with base plates or castor wheels. Above a certain height stabilisers or outriggers will be required. Working areas at the top or intermediate level are provided by platform units, around which will be guardrails and toeboards for safety.

3.2 Access to the platform can be by:

- Inclined or vertical ladders attached to the frame structure
- Vertical ladders built into the end frame. The cross rungs of the vertical end frame can be treated as a vertical built in ladder provided the rungs are spaced at intervals of between 230mm and 300mm, have a diameter less than 51mm and have anti-slip surface.
- Stairway where frequent access is envisaged, and carrying up of materials is required.
- Stairladder, where infrequent access is envisaged and materials do not have to be carried up.

The access provided depends upon the type of towers selected and will vary with different suppliers designs. See illustrations on page 3.

3.3 Horizontal, and diagonal braces will generally be identical except in length. The length and purpose of the brace may be marked clearly on it by an identifying label and/or colour coding. These braces will have a locking hook mechanism on the ends, which is used to lock onto the horizontal or vertical members of the frames. The braces cannot be removed until the hook mechanism is unlocked.

3.4 Platform units normally comprise an aluminium frame with two hooks at each end. Platform hooks locate over the horizontal members of the frames of the tower and are normally provided with locking mechanisms to prevent wind uplift. A platform surface will be fixed to the frame, which will normally be of plywood, having a special anti-slip surface. Some of the platform units will usually have a hinged hatch to allow access within the tower.

Platform units are normally about 600mm (24") wide and are available in length to suit the modular length of the tower.

Platforms can be single units or two units side by side. For intermediate or landing access platforms a single unit would generally be used, but for maximum safety (ie on working platforms) two units are desirable. The Construction (Health, Safety & Welfare) Regulations 1996 Schedule 1(3) require "The main guardrail or other similar means of protection shall be at least 910 mm above the edge from which any person can fall." Schedule 1(4) "there shall not be an unprotected gap exceeding 470mm between any guardrail, toeboard, barrier or other similar means of protection." Schedule 1(5) "Toeboards or other similar means of protection shall not be less than 150mm high." BS 1139 Part 3 1994 7.5.2 gives details of side protection dimensions, the only difference is that BS shows the upper handrail with the top surface 1000 ±50mm above the level of the platform. PASMA recommend the standard required by the Construction (Health, Safety & Welfare) Regulations 1996 but with the upper handrail top surface of 1000 ±50mm.

The Construction (Health, Safety & Welfare) Regulations 1996 - 6(9) state "No toeboards shall be required in respect of any stairway, or any rest platform forming part of a scaffold, where such stairway or platform is used solely as a means of access or egress from any place of work, provided that stairway or platform is not being used for the keeping or storing of any material or substance."

Fig. 1

FOUR TYPICAL TYPES OF PREFABRICATED ALUMINIUM ALLOY TOWERS

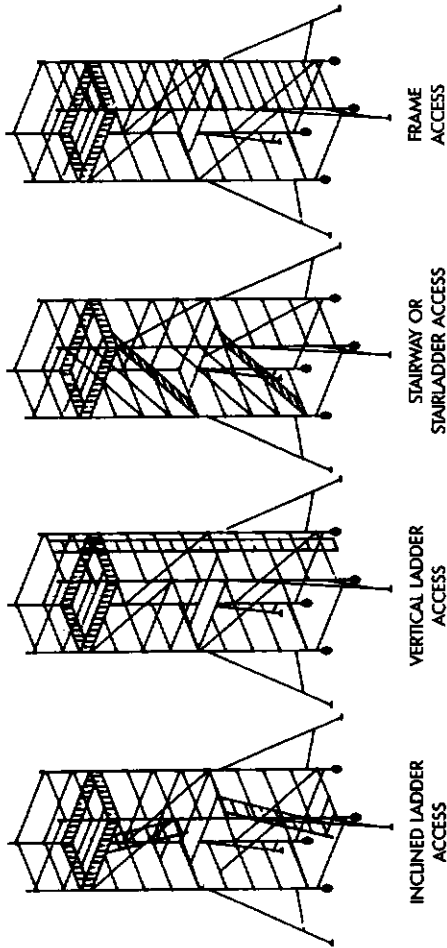
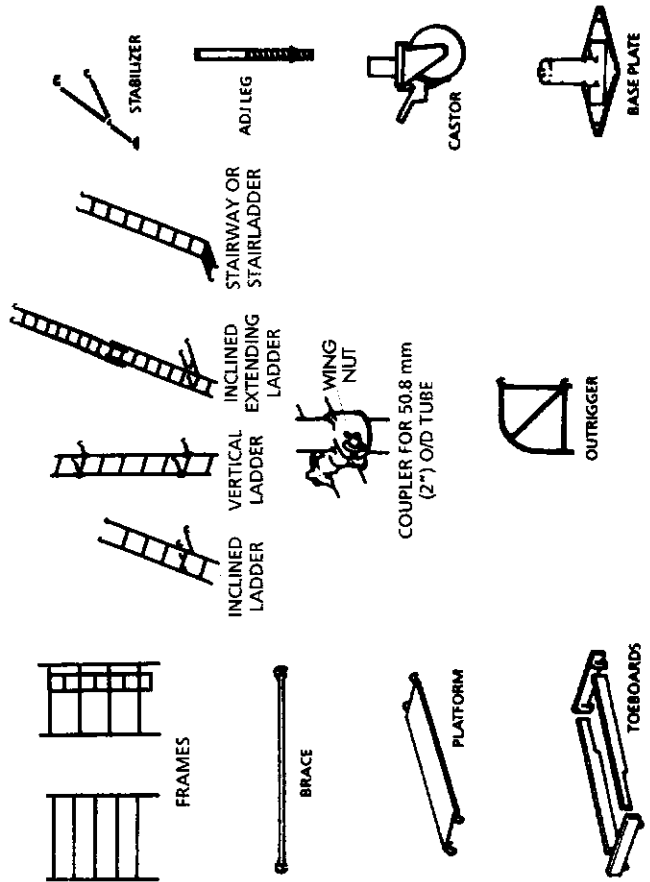

FIG. 1A TYPICAL TOWER COMPONENTS



10. REGULATIONS, STANDARDS AND RECOMMENDATIONS

10.1 Kitemarked or equivalent aluminium alloy towers must conform to the statutory requirements of the Construction (Health, Safety & Welfare) Regulations 1996 and the current British Standard (European Harmonisation Document HD 1004). The principal points in the regulations relate to safety of the structure and the provision of guardrails and toeboards, the width of the working platforms and the use of ladders on scaffolds. Tower designs supplied by PASMA member companies will conform to all these requirements, provided the components are erected and used in accordance with the instruction manual.

10.2 Recommendations for the design and performance of aluminium alloy towers are contained in British Standard 1139 (HD1004). Towers supplied by PASMA member companies conform fully with these requirements and are marked with the British Standard Kitemark of Approval, Testguard, German GS Mark or equivalent European accreditation bodies.

Rules and Guidelines for the preparation of instruction manuals contained in BS EN 1298.

This PASMA code of practice is intended to satisfy the following statutory regulations, standards and recommendations applicable to prefabricated aluminium scaffold towers.

- a British Standard BS1139 Part 3 1994 enactment of European Harmonisation Document 1004 1992.
- b The Health and Safety at Work Act 1974 Section 6
- c The Construction (Health, Safety & Welfare) Regulations 1996

9. CARE AND MAINTENANCE

9.1 Those regularly check for the care and maintenance of aluminium alloy towers should regularly check the inspection points outlined in section 8. Additionally inspection should periodically be made of all tower components, joints, rivets and locking devices. Any defects should be made good before the component is used further. Very few parts in aluminium alloy towers need lubrication but if the supplier recommends it, the mechanism for locking hooks, adjustable legs and castors should be lubricated with a suitable lubricant.

9.2 WARNING

REPAIRS SHOULD ONLY BE CARRIED OUT BY THE SUPPLIER OR OTHER COMPETENT PERSON APPROVED BY THE SUPPLIER.

Platforms should not be painted or treated subsequent to manufacture in a way which may conceal defects. Any instruction signs should be checked and replaced as necessary.

9.3 Handling, Transport and Storage

The life of aluminium alloy towers will be increased if proper care is taken of them during handling, erection, transportation and storage. Before storage components should be cleaned. Any concrete or corrosive substance should be removed.

Proper stacking will reduce any damage, and will make identification of the components easier for re-issue.

Similarly during transportation equipment should be properly stacked on vehicles. Space can be saved by systematically placing braces, platforms stairways etc in available space within vertically stacked frames.

3.5 The width of the basic tower is governed by the width of the end frames and typically these are available in two widths: Single Width and Double Width of approx. 0.75m and 1.3m respectively. The length of the basic tower can be varied by the length of braces and platforms. These range from 1.5m to 3.2m.

3.6 Outriggers and stabilisers may be attached to increase the EFFECTIVE BASE AREA and to improve stability (see section 5).

An outrigger is a device for use on towers which are to be moved frequently and has provision for an adjustable leg and castor.

A stabiliser is a similar device to be used on towers that are moved less frequently and has a self aligning foot in lieu of a castor.

4. ERECTION AND DISMANTLING

4.1 Instruction Manuals

All PASMA members supply comprehensive manuals on the erection/dismantling of towers which will comply with BS EN 1298 whether the tower is supplied on a hire or sale basis.

SUPPLIERS AND USERS SHOULD ENSURE THAT THESE MANUALS ARE AVAILABLE TO THE OPERATIVES ERECTING AND USING THE TOWER, AND TO THE PERSON SUPERVISING THE WORK. USERS SHOULD ALSO ENSURE THAT THE OPERATIVES ERECTING THE TOWER ARE COMPETENT TO DO SO BY SPECIAL TRAINING (OR ARE SUPERVISED BY SUCH A PERSON) (see training section 11). PASMA have designed a recognised certification system for this purpose.

4.2 Type and Number of Components

The type of components used for the construction of a tower must be compatible. Not only should they all be components from the same supplier, they should also be those recommended for the particular tower configuration. Suppliers usually provide a range of different types of towers and although some components are interchangeable between types, this is not always the case and unsuitable components should be rejected. Before commencing to erect the tower make sure that the correct number of components are available and never attempt to make up deficiencies by the use of alternative suppliers parts or random scaffold tubes, couplers or scaffold boards etc.

4.3 Ground Surface

Towers should be erected and used only on ground suitable for the purpose, generally with a surface of concrete, tarmacadam or similar. Where towers are on soft or uneven ground, base plates should be used instead of castors, and these should be set on boards or other decking which will provide a firm foundation. Outriggers and stabilisers should be similarly treated.

4.4 Castors, Base Plates and Adjustable Legs

Erection is usually commenced by fitting either castors or baseplates to four adjustable legs. The design includes a feature to prevent the castor or base

plate from falling out of the adjustable leg. The adjustable legs are fitted into the lower ends of the columns of two frames. A mechanism prevents the adjustable leg from falling out of the frames. Each leg has a device to vary its extension, so that the tower can be made level on uneven or stepped surfaces. THIS IS NOT a means of gaining additional height and the extension of the adjustable leg should be the minimum possible. Where adjustment is required beyond that for normal levelling purposes, consideration should be given to 4.5 (offset frame) below, after which the supplier's advice must be sought.

4.5 Base Section

The base section comprising the two frames and braces, is then assembled according to the supplier's instructions. The legs should then be adjusted so that the base section is vertical and the two end frames are at the same level. It is therefore preferable that the tower be erected in the position in which it is to be first used, otherwise the tower may have to be re-levelled when it is moved into the working position. If castors are used these should now be braked. For tiered floor situations the frames can be at offset levels as recommended by the supplier. Generally these offset frames will require extra diagonal bracing which should be placed in the positions as in the supplier's manual. If stabilisers or outriggers are required they must now be securely located (see section 5).

4.6 Upper Sections

The upper sections of the tower can now be erected following the sequence in the supplier's manual. Attention must be given to the following points:- Frames are connected by a spigot and socket joint with a locking mechanism which must be positively engaged. All other tower components must be fitted in the correct positional sequence - without omissions.

Lifting Components

The supplier's manual will give the recommended methods for lifting components.

4.7 Braces

Diagonal and horizontal (handrail) braces have locking hook mechanisms which engage with either horizontal or vertical frame members.

When fitted to horizontal members locking hooks must have their aperture facing downwards. When horizontal braces are fitted to verticals ensure that locking hooks have their aperture facing outboard. In all cases when fitting braces ensure that the hook mechanisms have operated correctly and that the brace is securely fixed to the frame.

4.8 Platforms

All platform units have hooks at each end which locate onto the horizontal members of frames. Ensure that these are properly positioned and that the platform sits firmly and squarely in place. If platforms have a full access hatch ensure that the hinge is outboard. The windlock device should be engaged. Platforms must be installed at least every 4 metres in height.

- Check that outriggers or stabilisers are correctly positioned and secured, as close as possible to the underside of the castings or cross-member.
- Check that all baseplates or castor wheels are fully in contact with the ground including those on outriggers. Stabiliser feet should rest firmly on the ground. Check that all castors and adjustment devices are secured.
- Check that all the spigot and socket joint locks holding the frames together are secured.
- Check that all the bracing members have been located exactly in accordance with the instruction in the supplier's manual.
- Check that all windlock clips on platforms are in position.
- Check that all guardrails and toeboards are in position as required.
- Check that all access stairways and ladders are in position and are firmly located.

8.3 During use of the Tower

During use, the tower should be kept in good working order. For ongoing use, a competent person should inspect the tower weekly or after inclement weather (in accordance with Safety Regulations) to see that the structure is still safe to use. Should parts become damaged they should be replaced before the tower is used again.

8. INSPECTION

8.1 Before Erection of Tower

Ensure that the operatives erecting the tower have received proper training to a certificated standard.

Before using a tower, all components should be checked to see that they are in good condition, are compatible (from the same manufacturer) and that all joints are sound.

Castors should be inserted and checked to see that in each case the castor housing and wheel/tyre is not damaged, that the wheel rotates readily, that the castor swivel rotates effectively, the mechanism for retaining the castor in the leg will support the castor's weight and that the brake functions properly.

Adjustable legs should be checked to see that they are not bent or the thread damaged. All threads should be clean and free from debris. The adjustable leg device should be inserted and removed to see that the securing device operates effectively.

Frames should be checked to see that the members are straight and that joints and welds are undamaged. They should be free of extraneous material such as concrete. Spigots should be straight and parallel with the axis of the column tube and the device for locking frames together should be checked to see that it is functioning correctly.

Similarly braces, stairways and ladders should be checked to see that they are straight and undamaged and locking hook mechanisms should be checked to see that they are functioning correctly.

Platforms should be checked to see that they are undamaged and that the frames are square and true. Plywood decks should not be split or warped and should be firmly fixed to the frames. Where toeboards incorporate clips or fittings these should be undamaged and firmly fixed to the toeboard. Ancillary parts, such as outriggers and stabilisers should be checked for damage and effective functioning of hooks and couplers. Any labels should be intact and legible.

8.2 Before Use of Tower

Whilst the tower is being erected, the following checks should be made as the erection proceeds:

Check that it is vertical and square and that the horizontal braces and platforms are horizontal.

4.9 Guardrails and Toeboards

Working platforms must be fitted with guardrails and toeboards and care should be taken to see that these are correctly fitted in accordance with the supplier's instructions, which will comply with the height requirements of BS1139 Part 3 1994 (HD1004), which specify:

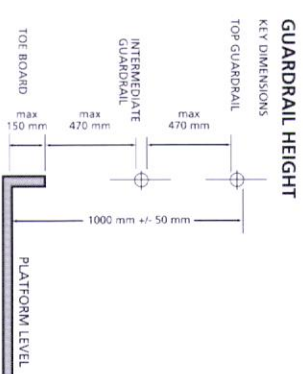

Top guardrail height 1000mm +/- 50mm above platform level

There shall not be an unprotected gap exceeding 470mm between any guardrail, toeboard, barrier, or any other means of protection. If the tower is unable to comply with the dimensions shown in this paragraph, a special guardrail frame should be employed to obtain the correct guardrail level.
Minimum toeboard height: 150mm

4.10 Scaffold Couplers.

Most PASMA towers have tubes of larger diameter than standard scaffold tube. Standard scaffold couplers are not therefore suitable for coupling to PASMA towers. If steel or aluminium scaffold tubes are connected to tower structures, possibly to provide a stabilising tie the user should ensure that the coupler used is suitable, i.e. one that will accept the two different sizes of tube. These are available from PASMA members.

4.11 Means of Access

Access to the platform must be provided by integral/vertical ladders, stairladders, inclined ladders or stairways. These should be erected as shown in the supplier's instructions. If materials are to be carried or frequent vertical movement required, a stairway should be used. **EXTERNAL LADDERS MUST NEVER BE USED WITH ALUMINIUM OR FIBREGLASS TOWERS.**

	INCLINATION	CLEAR	WIDTH
Integral/vertical Ladders		280mm	
Stairladders	35-55 deg.	280mm	
Inclined Ladders	60-75 deg.	280mm	
Stairways	35-55 deg.	400mm	

Access to or through fully decked platform levels must be via a hatch (min. size 400 x 600mm) which must be capable of being secured in the closed position.

The first step onto the tower should not exceed 400mm, unless the first step is a platform, when it should not exceed 600mm.

4.12 Rest Platforms

If materials are to be stored on rest platforms then double guardrails and toeboards must be provided.

5. STABILITY OF TOWERS

5.1 General

The major reason for selecting aluminium alloy towers to provide access is the lightness of the components and the consequent ease of assembly compared to the heavier sections of steel scaffold structures. In mobile form aluminium towers are easy to move from point to point, but the lightness of the structure means that care has to be taken to ensure the stability of the tower. The manual the supplier provides, will show the safe height to which various tower configurations can be erected, and will give information on the use of stabilisers and outriggers to increase the stability of high towers. If these instructions are observed, aluminium alloy towers provide a stable and firm work platform for a wide variety of applications.

The illustration shows the optimum positions for stabilisers - for fuller information contact your supplier.

Fig. 3
TOWER WITH
OUTRIGGERS

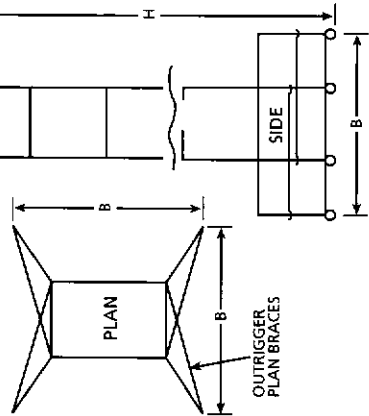
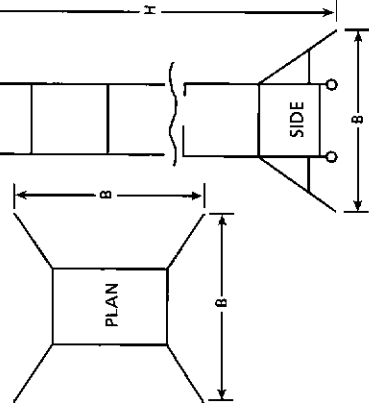

Fig. 4
TOWER WITH
STABILISERS



Safety Check List (Continued)

- 17) Do fix a warning notice if the tower is to be left incomplete.
- 18) Do not build to a height greater than the manufacturer's manual indicates is safe.
- 19) Do not erect on ground incapable of supporting the tower.
- 20) Do not use the adjustable legs to gain additional height.
- 21) Do not use or move the tower on sloping or obstructed surfaces, without attention to vertical alignment and stability.
- 22) Do not use a tower which is not vertical.
- 23) Do not move the tower carelessly - by pulling it along at working platform level.
- 24) Do not move the tower with men or materials on the structure.
- 25) Do not move the tower by any mechanical means.
- 26) Do not lift materials or equipment outside the base area of the tower.
- 27) Do not use the tower in adverse weather conditions.
- 28) Do not use a mobile tower when the castor wheels have not been locked.
- 29) Do not exceed the Maximum Design Load.
- 30) Do not use sheeting around the tower.
- 31) Do not extend the height of the top platform by the use of ladders, boxes or other devices.
- 32) Do not climb from the tower into a nearby building, or vice versa.
- 33) Do not climb up the rungs of the frames unless they are of the accepted spacings.
- 34) Do not use a tower in the vicinity of overhead electrical lines. They are not normally insulated, are dangerous and you should keep well clear.

7. HAZARDS

Accidents are normally the result of carelessness or failure to observe good working practice. With Mobile Access Towers accidents can be caused by not following common sense procedures:

Safety Check List

7.1

- 1) Do ensure that the supplier's manual is on site and has been read and understood.
- 2) Do ensure that all the components are there, and of the same make.
- 3) Do avoid using damaged, incorrect or incompatible components
- 4) Do check that all components are working properly.
- 5) Do check that the ground is level, and unobstructed.
- 6) Do check that castors are locked.
- 7) Do use outriggers or stabilisers when required.
- 8) Do ensure frame interlock systems are fully engaged.
- 9) Do tie towers into a building or adjacent structure when they should be.
- 10) Do ensure the ground is clear of obstructions, potholes, ducts etc.
- 11) Do ensure the tower is clear of overhead obstructions.
- 12) Do see that bracing members are fitted in accordance with instructions.
- 13) Do fit guardrails and toeboards, which prevent men or materials falling from the platforms.
- 14) Do be careful of strong horizontal forces at working platform level, such as percussion tools etc.
- 15) Do inspect before each use.
- 16) Do take precautions in industrial areas, housing estates, public places etc. like fencing the base of the tower to prevent children or vandals from climbing the tower and vehicles colliding with the tower.

5.2 Height Calculations (Height to Base Ratio)

It is no longer appropriate to apply the simple rule of thumb measure of 3 x minimum base dimension for external use (or 3.5 internal) as the tower structures perform in different ways in tests and calculations. For this purpose you should refer to the supplier's assembly instructions which will show the quantities of material required for each height of tower, and the stabiliser requirements. However, as a general rule, stabilisers or outriggers will be required once a tower has been built beyond its first frame level.

5.3 WIND

Information about the effect of wind on towers and the safe conditions in which they can be used is contained in the following section of this PASMA Code of Practice.

Be cautious about the use of towers in open ended buildings, such as hangars or unclad buildings, as the wind forces in such locations can often be greater than if the towers are used outside the building, due to the funnelling effect of the wind.

5.4 Wind Loads on the Tower (Free Standing Towers)

Wind imposes a horizontal load on the tower tending to overturn it. In normal safe working conditions this tendency to overturn is counteracted by the self-weight of the tower, and the stabilising effect of the outriggers or stabilisers. BS1139 Part 3 1994 (HD1004) states that towers must be stable in a free-standing condition in a wind pressure that equates to 28 mph or Beaufort force 6. If the wind speed should exceed 17mph you should cease to work upon the tower. **If the wind speed reaches 25mph the tower should be tied into a rigid structure, and if it is likely to reach 40mph, the tower should be dismantled.**

Towers erected in accordance with this code are safe to be used in winds up to these speeds when the specific recommendations of the supplier are followed.

5.5 Other Horizontal Loads

Apart from wind loads, other horizontal loads can act on the tower. These are mainly caused by the actions of operatives working on the tower. For example, when using hand tools, such as a drill, pushing on the drill causes an equal and opposite force on the tower. Such forces should be avoided as much as possible and in no circumstances should they exceed 20kg (44lb) on free standing towers.

It is hazardous to move towers by pulling them along from the platform. Towers must only be moved by application of manual effort at or near the base and there should be neither men nor materials on the tower during the moving operation (See section 6.6 - moving towers).

5.6 Vertical Eccentric Loads (Lifting Material etc.)

Any vertical load outside the area of the tower can be hazardous. For example, heavy materials hoisted outside the effective base area of the tower have a tendency to overturn the tower particularly if no outriggers or stabilisers are fitted as can be the case with towers of lower height.

Loads must be hoisted within the EFFECTIVE BASE AREA of the tower (ie within the area bounded by the tower or stabilisers/outriggers where fitted.) The advice of the supplier's must be sought about hoisting loads to ensure safe and stable use of the tower.

5.7 Outriggers and Stabilisers

Outriggers or stabilisers increase the EFFECTIVE BASE DIMENSION of the tower and must always be fitted when required by the supplier's instruction manual.

5.8 Sheeted Towers

On occasions it is necessary to enclose the frame of the tower with some form of sheeting. This greatly increases the effect of wind on the tower thus reducing the stability. This will mean that such towers must be tied in at all times and the advice of the supplier should be sought.

5.9 Tying-in

Aluminium alloy towers are supplied as free-standing units for heights to the working platform of 12.0m and some suppliers provide special towers that are free standing up to 16m. Towers above these heights where the optimum base dimensions cannot be constructed, will have to be rigidly tied into an adjacent structure and the advice of the supplier should be sought.

Tying-in is normally achieved with aluminium or steel tubes and compatible couplers, but the advice of your supplier must be sought.

It is safe practice to tie in towers of all heights wherever possible. However where towers are left unattended or are to be located in particularly exposed conditions, stability will almost certainly be affected by wind forces. In these circumstances ensure that the tower is adequately tied in or restrained from blowing over and that the platforms are securely fixed, or alternatively the tower dismantled.

5.10 Use as Facade Scaffolds

These are outside of the scope of this document and HD1004 and should only be erected to the manufacturer's instructions and the recommendation of BS5973:1993 or HD1000.

6.7 Cantilever Platforms

Cantilever platforms can be attached to towers. Such structures must be erected in accordance with the supplier's instructions. Never attempt to make cantilever platforms by impromptu methods chosen on site. The design must be approved by the manufacturer.

They will have a restricted safe working load based on an acceptable factor of safety.

6.8 Use of Scaffold Boards and Stagings

Do not make up deck areas for the tower by using standard scaffold boards. However it is sometimes useful to be able to bridge between two adjacent towers with proprietary staging units. If this is done, care should be taken to see that the towers are effectively stabilised and prevented from moving. The staging should be firmly supported on a load bearing part of the tower and prevented from moving during use - a minimum of 600mm oversail on either end support should be provided. If the unit is purpose-designed with integral hooks for attachment to the tubular transom, this oversail is not required. Guardrails and toeboards must be provided to stagings.

Care should be taken when using stagings that the effective maximum design load on the tower and stability requirements are complied with, and that working platform widths regulations of 600mm minimum width are complied with which will often require a minimum of two staging units. If in doubt consult your supplier.

6.6 Moving Towers

Towers must never be moved with men or materials anywhere on the tower and must only be moved by applying manual force at or near the base of the tower. Never move towers with powered vehicles. Never move towers in high wind conditions. Take care the tower is clear of overhead obstructions, particularly electric cables.

If a tower has to be suspended the supplier should be consulted before this is done.

It is preferable to use outriggers rather than stabilisers if a tower has to be moved frequently.

ENSURE ANY HOLES, DUCTS, PITS OR GRATING ARE SECURELY COVERED.

MOVING TOWERS

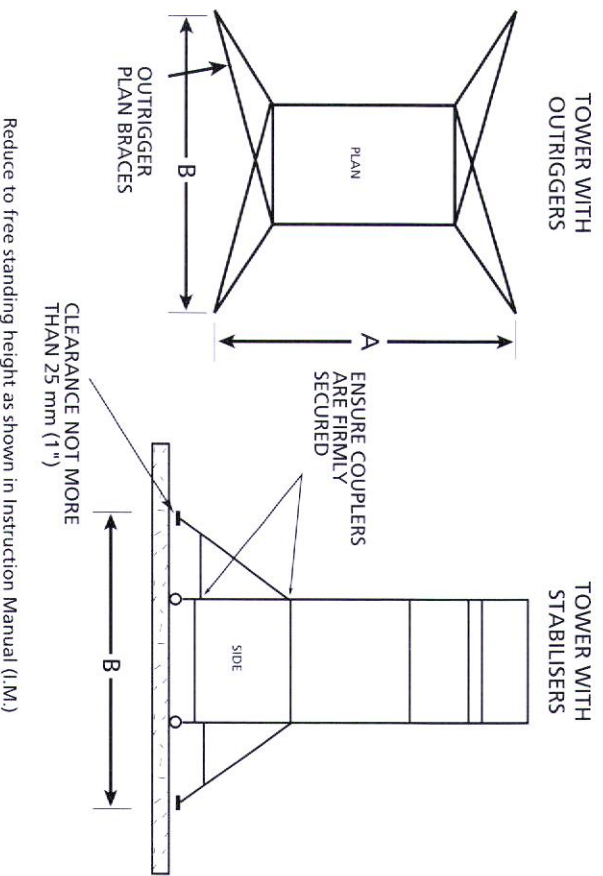

TIE ARRANGEMENTS

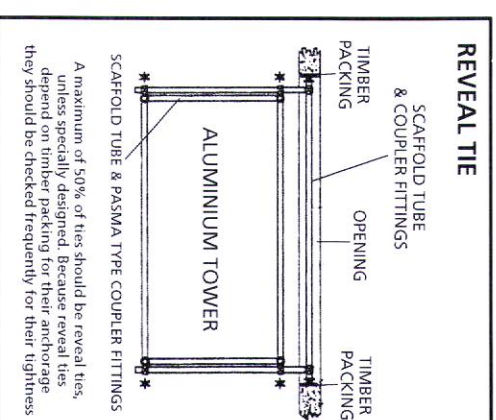
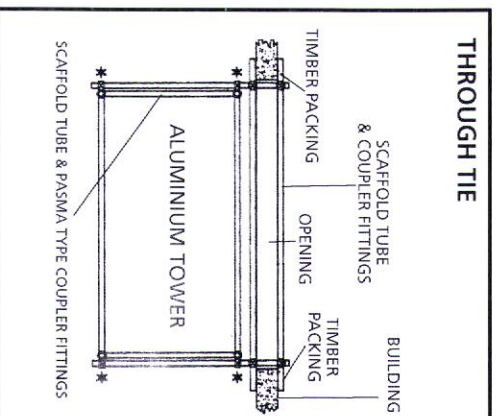
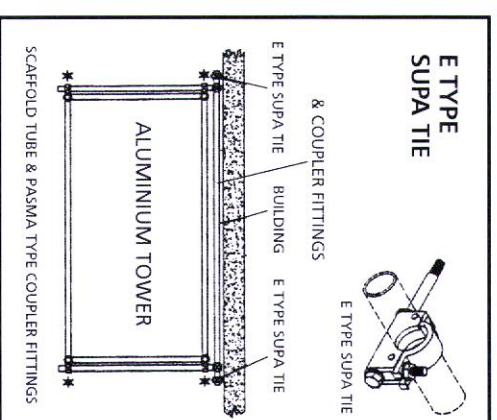
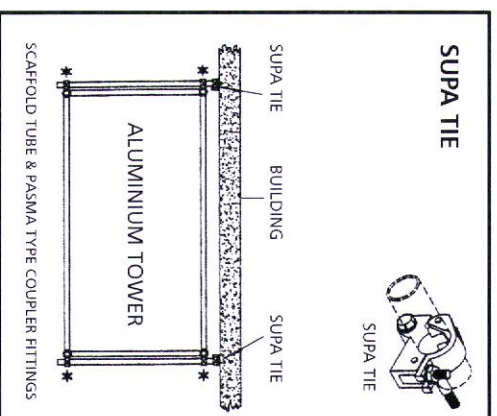

* Ensure use of correct coupler fitting if scaffold tube (48.3mm diameter) and aluminium tower tube (50.8mm diameter) interface.

Use of Tube and Couplers.

The advice of the supplier should be sought to advise on suitable methods of abutting towers especially where buildings have large glazed or clad faces, or when used in gangways against high racking.

5.11 Ballast Weights, Guy Ropes and Ground Anchors

Where additional stability is required, but cannot be achieved by tying into a rigid structure then it is possible to obtain stability by the use of ballast weights, guy ropes or ground anchors. Ballast must be of solid materials (ie. not sand or water) and must be securely attached to the tower structure.

Ballast weights placed on to the base of the structure will increase tower self-weight, thereby increasing stability. Your supplier or other competent person should specify the correct amount of ballast weight and care should be taken to see that the total safe load on the structure, and particularly on the castors, is not exceeded.

It is inadvisable to use guy ropes for stability unless under specialist direction.

The tower can be secured to the ground by ground anchors, anchor bolts or spikes. Anchors should be of adequate strength and the method of attachment to the tower must be as specified by the supplier.

5.12 Towers in Public Places

When towers are left erected in public places, or where vandals can gain access to the towers, it is advisable to provide security fencing around the tower base to a suitable height to prevent access, and tie in whenever possible.

In certain locations, a pavement licence may be required from the local authority, which may impose special conditions such as the use of pavement frames, lighting, etc.

6. SAFE USE OF TOWERS

6.1 General

Mobile Access Towers provide a safe and effective working platform, provided that certain simple rules are observed.

6.2 Guardrails and Toeboards

Statutory regulations require that all working platforms, or platforms where goods are stored, are provided with guardrails and toeboards. Your tower supplier will have made available suitable guardrails and toeboards which satisfy these requirements and they must be used at all times and they must be positioned in accordance with the instructions in the instruction manual. Do not be tempted to leave out guardrails/toeboards to give easier access for working.

6.3 Platforms

The platforms supplied with Mobile Access Towers are specially designed for the purpose and locate securely on the frames of the tower. Ensure that all hooks are properly engaged with their supports and see that the platforms are level and firmly seated.

6.4 Safe Loading

The supplier's instruction manual will detail the maximum loads that the tower can support. Generally speaking they will show the Maximum Design Load that can be supported on any platform and the maximum design load that can be supported by the tower as a whole (ie. the sum of the working loads from several different platforms together with the tower self weight). The castors must have their maximum design load clearly marked on them. It is recommended that a notice be exhibited at the base of the tower, showing the maximum design load, so that all personnel who use the tower are aware of its safe capacity.

The self weight of the tower must be subtracted from the SWL on all towers to establish the net load capacity.

6.5 Incomplete Towers

When towers are left in an incomplete state, a notice should be displayed to announce the fact. This notice should read:

DANGER
INCOMPLETE SCAFFOLD
NOT TO BE USED