

PASMA

Contact PASMA at:

The Secretary
PASMA
P.O.Box 1828
West Mersea
Essex
CO5 8HY

Tel: and Fax: 01206 382666
Email: info@pasma.co.uk
www.pasma.co.uk

OPERATOR'S CODE OF PRACTICE

Applies only to Prefabricated Towers,
manufactured in aluminium alloy or
fibreglass, approved to BS1139 Part 3 1994
(HD 1004) and which carry a current British
Standard or other equivalent mark of approval

PRICE £5.00

PUBLISHED JANUARY
(9TH REVISION)

www.pasma.co.uk

THE N 100 : 2000 - 007

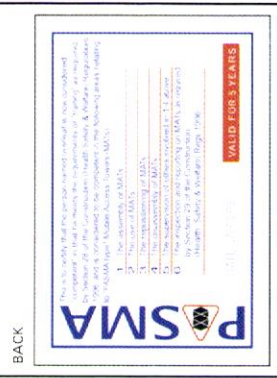
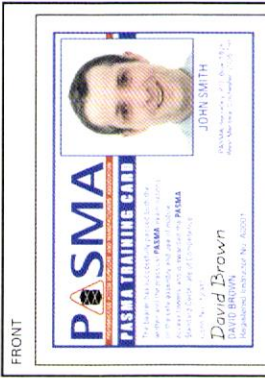

© PASMA 2002

The contents of this Code of Practice are the copyright of PASMA, (Prefabricated Access Suppliers' and Manufacturers' Association Ltd). No unauthorised reproduction or copying is permitted without the express written permission of the copyright holder.

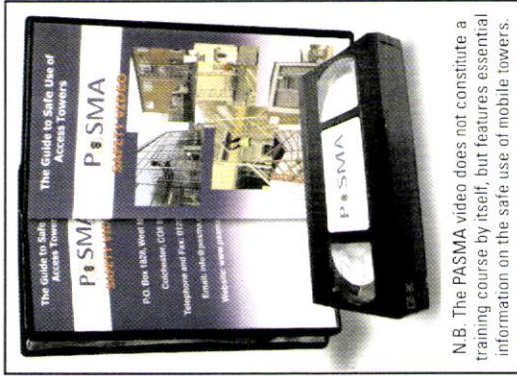

N.B. The PASMA video does not constitute a training course by itself, but features essential information on the safe use of mobile towers.



PASMA INSPECTION LABELS

PASMA TRAINING – ADVANCED COURSES

PASMA Approved Training Centres also provide a series of Advanced Training Courses covering the more advanced uses of towers and ancillary equipment

- 1 Chimney Scaffolds
- 2 Cantilever Access Towers
- 3 Aluminium Bridging Units, Linked Towers, Lightweight Stagings and Swimming Pool Bridges
- 4 Access Towers With Walk Through Frames, High Clearance Frames On Footways And Access Towers On Stairways



These are available in modular form and are intended for the more experienced PASMA operative who has completed the Standard Course.

PASMA training is available only from PASMA Approved Training Centres.

PASMA have produced a video in support of its aims to encourage the safe use of mobile access towers.

For more details of all PASMA training courses, to purchase more copies of this Code of Practice, or to purchase a copy of the PASMA video, contact your PASMA Approved Training Centre or contact the Secretary at the address on the back cover.

18.1 Assembly Check-list

1. Check that you have a copy of the manufacturer/suppliers instruction manual on site and that it has been read and understood.
2. Check the risk assessment document.
3. Ensure that all the components are present for the height you wish to reach, of the same make, and are undamaged.
4. Lay out the components and check that all castors are locked.
5. Follow the steps outlined in the Instruction Manual, ensuring that:
 - CASTORS LOCKED/LEGS CORRECTLY ADJUSTED
 - BRACES & PLATFORM LEVEL
 - TOWER UPRIGHT
 - STABILISERS/OUTRIGGERS FITTED AS SPECIFIED
 - PLATFORMS LOCATED & WINDLOCKS ON
 - HANDRAILS IN PLACE
 - TOEBOARDS LOCATED
 - INSPECT TOWER PRIOR TO USE

19. PASMA TRAINING SCHEME

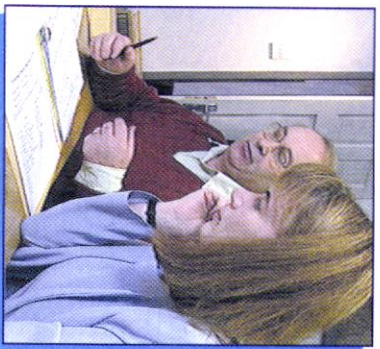

As well as being the lead industry body, the organisation consulted by British & European standards agencies, the HSE and the people to whom users, managers and safety professionals turn for expert advice, PASMA also operates a national training scheme through a network of Approved Training Centres. Training Centres have to meet an exacting set of criteria before they can become PASMA Approved. Instructors are vetted, premises and facilities, course materials and equipment all have to meet exacting standards. Moreover, they are subject to ongoing audit to ensure they continue to meet consistently high standards.

This Code of Practice as well as being a definitive stand alone reference document also serves as support reference for the PASMA Standard Training scheme. It forms part of a nationally recognised one day training course in the PASMA Training Scheme for operatives, supervisors and managers in the safe assembly, use, inspection repositioning and dismantling of mobile access towers. Successful delegates receive a PASMA certificate and convenient photocard as proof of competence.

CONTENTS

1. Foreword	1	12.8	Instability – Moving by vehicles	17
2. Introduction	2	12.9	Instability – Ground Conditions	19
3. Scope	2	12.10	Instability – Over-extension of adjustable legs	17
4. Safety Requirements	3	12.11	Instability – Vertical Alignment	17
4.1 Legislation	3	12.12	Structural Failure - Overloading	17
4.2 Regulations	3	12.13	Structural Failure – Incorrect Assembly	18
4.3 Guidance	3	12.14	Falls from Height – Improper Use of Guardrails	18
4.4 Standards	3	12.15	Falls from Height – Over-reaching	18
5. User's Qualifications & Responsibilities	4	12.16	Falls from Height – Climbing Outside of Tower	19
5.1 Training	4	12.17	Falls from Height – During Assembly & Dismantle	19
5.2 Literacy, Fitness & Health	4	12.18	Falls from Height – Fall Protection	19
5.3 User's responsibilities	4	12.19	Working in Public Places	19
6. Types of Mobile Access Towers	5	13.1	Safe Use of Towers	20
7. Components	6	13.2	Safe Loads	20
8. Assembling the Tower	8	13.3	Incomplete Towers	20
8.1 Instruction Manuals	8	13.4	Cantilever Platforms	20
8.2 Type & Number of Components	8	14.	Linked/Bridged Towers	21
8.3 Suitability of Site – Ground Conditions	8	14.1	Care and Maintenance	21
8.4 Castors, Base Plates & Adjustable Legs	8	15.	Inspection Check-list	21
8.5 Base Module	9	16.	Repairs	21
8.6 Upper Modules	9	16.	Handling, Transport and Storage	22
8.7 Braces	9	17.	Safe Systems of Work	22
8.8 Platforms	10	18.	Site Inspection	22
8.9 Guardrails and Toeboards	10	18.1	Assembly Check-list	23
8.10 Method of Access	10	19.	PASMA Training Scheme	23
8.11 Stability	11		Advanced Courses	24
9. Moving the Tower	12			
10. Tying in the Tower	12			
10.1 Ballast Weights, Guy Ropes and Ground Anchors	13			
11. Dismantling the Tower	14			
12. Hazards	14			
12.1 Slips	14			
12.2 Electrocution	14			
12.3 Striking by vehicles	15			
12.4 Falling Objects	15			
12.5 Instability – Effects of Wind	15			
12.6 Instability – Side Loads	16			
12.7 Instability – Vertical Loads	16			

1. FOREWORD

There is one organisation which is solely committed to the safe use of mobile access towers, PASMA, the Prefabricated Access Suppliers' & Manufacturers' Association.

PASMA has long been committed to the ideals of providing safe, efficient access and equipping operatives with the necessary information and training to allow them to use mobile access towers safely and productively.

This latest revision of the Code of Practice is in an entirely new format and incorporates the most recent changes in regulations and guidance.

In addition to its function as a stand alone reference document for users, their supervisors and managers, as well as Health & Safety professionals, it is also intended to supplement PASMA approved training courses by serving as a worthwhile reminder of the good practices that delegates have learned during training and work experience.

By following the practical guidance of this revised Code of Practice, the operative is able to call on the combined experience of the entire mobile access tower industry, since PASMA's members, with a wealth of experience between them, have contributed to its production in the interests of promoting the safer and more efficient use of mobile access towers throughout industry.

The Association extends its grateful thanks to those dedicated committee and council members whose efforts ensure that PASMA continues to meet its stated commitment to the safe use of mobile access towers.

Peter Bennett

Code of Practice Review Team
PASMA
January 2002

16. HANDLING, TRANSPORT AND STORAGE

The life of mobile access towers will be increased if proper care is taken of them during handling, erection, transportation and storage. Before storage components should be dismantled, checked and cleaned. Any concrete or corrosive substance should be removed. Proper stacking will reduce any damage, and will make identification of the components easier for re-issue. Similarly during transportation equipment should be properly stacked on vehicles. Space can be saved by systematically placing braces, platforms, stairways and such like, in available space within vertically stacked frames.

17. SAFE SYSTEMS OF WORK

Safe use of access equipment relies on a number of factors.

You firstly need to select appropriate work equipment, equipment that gives you a safe working platform.

You next need to ensure you have safe systems of work, this means identifying the hazards, assessing the risks and taking the necessary steps to minimise them, and finally agreeing a safe system, written and agreed in the form of a method statement saying how the work will be undertaken.

18. SITE INSPECTION

Inspecting equipment and maintaining them in good condition is a mandatory requirement. Access towers must be inspected by a competent person.

If a tower is to remain erected for a period of 7 days, a written report must be completed before being used for the first time. Towers must also be inspected at regular intervals during use not exceeding every seven days, or when they have been altered, or after adverse weather conditions as required by current regulations.

Where the height of fall is less than 2 metres this is not required.

PASMA recommends the use of visible tag systems to record inspections.



14.1 CARE AND MAINTENANCE

Those responsible for the care and maintenance of mobile access towers should regularly check the equipment.

Inspection should periodically be made of all tower components, joints, rivets and locking devices. Any defects should be made good before the component is used further. Very few parts in mobile access towers need lubrication but if the supplier recommends it, the mechanism for locking hooks, adjustable legs and castors should be lubricated with a suitable lubricant.

14.2 INSPECTION CHECK-LIST

All components should be checked to ensure that they are in good condition, and that all joints are sound.

Castors should be inserted into the adjustable legs to check for wheel/tyre and housing damage, and that the wheel and swivel rotate freely. Examine the mechanism for retaining the castor in the leg and that the brake functions properly.

Adjustable legs should be checked to see that they are not bent or the thread damaged. All threads should be clean and free from debris. The adjustable leg device should be inserted and removed to see that the securing device operates effectively.

Frames should be carefully examined to see that the members are straight and that joints and welds are undamaged. They should be free of materials such as concrete. Spigots should be straight and parallel with the axis of the column tube and the device for locking frames together should be checked to see that it is functioning correctly.

Braces, stairways and ladders should be straight and undamaged, and the locking hook mechanisms should be functioning correctly. Ancillary parts such as stabilisers and outriggers should be checked in the same way.

Platforms should be checked to see that the frames are square and true, and there is no weld or other damage. Plywood decks should not be split or warped and should be firmly fixed into the frames. Toeboard clips or fittings should be undamaged and remain firmly fixed to the toeboard. Any labels should be intact and legible. Also see your manufacturer/suppliers Instruction Manual for guidance.

15 REPAIRS

**REPAIRS SHOULD ONLY BE
CARRIED OUT BY THE MANUFACTURER
OR OTHER COMPETENT PERSON
APPROVED BY THE MANUFACTURER.**

Platforms should not be painted or treated subsequent to manufacture in a way that may conceal defects. All signs should be checked and replaced as necessary.

2 INTRODUCTION

PASMA is an industry association for suppliers and manufacturers of mobile access towers consisting of Manufacturing, Hirer/Dealer and Training Members.

Manufacturing members must have product conformity certification to the latest British/European product standards accredited by a third party certification body such as British Standard Kitemark, TÜV or other equivalent mark of approval.

Hirer/Dealer members undertake, as a requirement of their membership, to have as the bulk of their stock, equipment which carries the British Standard Kitemark, TÜV or other equivalent mark of approval.

Training members, as well as conducting training using dedicated equipment which carries the mark of approval as described above, are also subject to initial assessment and ongoing audit to ensure they comply with the stringent requirements of the PASMA training scheme.

This edition of the PASMA Code of Practice takes account of the latest regulations, guidance and product standards, (refer to Safety Requirements section for details), at time of issue, and supersedes all previous editions.

Contact PASMA at:

The Secretary
PASMA
P.O. Box 1828
West Mersea
Essex CO5 8HY
Tel: and Fax: 01206 382666
e-mail: info@pasma.co.uk

Details of the PASMA membership can be found on the website
www.pasma.co.uk

3 SCOPE

This Code of Practice relates mainly to free-standing mobile access towers manufactured from prefabricated components where the principal structural materials are aluminium alloy or fibreglass and specifically refers to towers that have a British Standard or equivalent UK or European approval mark.

This type of mobile access tower system can also be assembled to form continuous facade scaffolds and special structures, such as portal frames, bridges etc, but these special structures are outside the scope of this Code and users must consult their supplier for further information.

The scope of the current product standard is limited to mobile prefabricated towers of height from 2.5m to 12m (indoors) and from 2.5m to 8m (outdoors).

This document should be used in conjunction with the appropriate manufacturer's instruction manual.

4. SAFETY REQUIREMENTS

This code of practice is based upon and incorporates the requirements of the following:

4.1 Legislation

Health & Safety at Work (etc.) Act (1974)

4.2 Regulations

Construction (Health, Safety & Welfare) Regulations (1996)
 Management of Health & Safety at Work Regulations (1999)
 Provision & Use of Work Equipment Regulations (1992)
 Personal Protective Equipment at Work Regulations (1992)
 Manual Handling Operations Regulations (1992)
 Reporting of Injuries, Diseases & Dangerous Occurrences Regulations (1995)

Copies of the above are available from your local HSE office.

4.3 Guidance

Health & Safety in Construction HS (G) 150
 HSE Information Sheet CIS 10

Copies of the above are available from your local HSE office.

4.4 Standards

BS 1139, Part 3 (1994), HD1004 : 1992
 BS EN 1298

Copies of standards can be obtained from:

British Standards Institution
 389 Chiswick High Road
 London
 W4 4AL



DIN 422 8/92:
 HD 1004-3-8/12



BS1139:PART 3:1994

13. SAFE USE OF TOWERS

13.1 Safe Loads

The supplier's instruction manual will detail the maximum loads that the tower can support. Generally speaking they will show the Maximum Design Load that can be supported on any platform and the maximum design load that can be supported by the tower as a whole (i.e. the sum of the working loads from several different platforms). The castors will have their maximum design load clearly marked on them. It is recommended that a notice be exhibited at the base of the tower, showing the maximum design load, so that all personnel who use the tower are aware of its safe capacity.

13.2 Incomplete Towers

When towers are left in an incomplete state, a notice should be displayed to announce the fact.



13.3 Cantilever Platforms

Cantilever platforms can be attached to towers. Such structures must be erected in accordance with the supplier's instructions. Never attempt to make cantilever platforms by impromptu methods chosen on site. The design must be approved by the manufacturer, which will have a restricted safe working load based on an acceptable factor of safety. PASMA's Advanced Training Scheme incorporates a module, which equips delegates to assemble such structures.

13.4 Linked/Bridged Towers

These are outside of the scope of this document and should only be erected according to the manufacturer's instructions and the recommendations of current standards. PASMA's Advanced Training Scheme incorporates a module, which equips delegates to assemble such structures.

PASMA recommends that all such advanced uses of mobile access towers are undertaken only by operatives who have undergone Advanced PASMA Training and are in possession of the appropriate certificate and photocard.

12.16 Falls from Height – Climbing Outside of Tower

Not only does this practice cause a risk of overturning, but, if you do lose your grip, or slip, there is nothing to prevent you falling.

12.17 Falls from Height – During Assembly & Dismantle

Whilst you are in the course of assembly and dismantling, you must be aware the hazard of falling from height does not go away. The assembly & dismantling procedure you use must also take account of preventing you from falling.

12.18 Falls from Height – Fall Protection

Both PASMA and the HSE specifically recommend that you do not attach safety harness lanyards to mobile access towers. In the event of an arrested fall, you are likely to cause the tower to overturn, not only increasing the risk of further injury to yourself, but also occasioning the additional risk of putting others in the vicinity in danger from the falling tower.

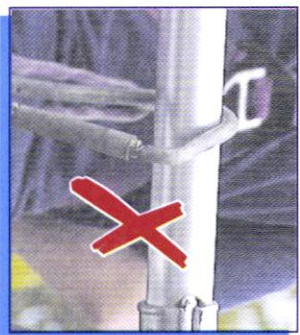

Some employers insist on the mandatory use of safety harnesses when working at height. Where an employer makes this a mandatory requirement you must ensure that the lanyard is always attached to a suitable anchor point outside the tower.

12.19 Working in Public Places

When towers are left erected and unattended in public places, or where vandals can gain access to the towers, it is advisable to provide security fencing around the tower base to a suitable height to prevent access, and tie in whenever possible.

In certain locations, a pavement licence may be required from the local authority, which may impose special conditions such as the use of pavement frames, lighting and such like. PASMA's Advanced Training Scheme incorporates a module, which equips delegates to assemble such structures.



5. USER'S QUALIFICATIONS & RESPONSIBILITIES

5.1 Training

The Construction Regulations require that you, (and your Supervisor and Manager) be trained in the safe use of work equipment, which includes mobile access towers. The PASMA photocard provides proof that you have undergone and successfully completed training to a nationally recognised standard. Many workplaces will insist on seeing your PASMA photo card before you will be allowed to assemble, move or dismantle mobile access towers, so it should be retained with you at all times and presented for inspection by anyone in authority.



5.2 Literacy, Fitness & Health

Since the safe use of mobile access towers requires that you consult safety notices and read and thoroughly understand the manufacturer's instruction manual, literacy is an important pre-requisite for any tower user.

Similarly, since the assembly and use of mobile access towers can be physically demanding, users should be physically fit and in good health and should, generally, not have problems with eyesight or hearing. (If you have any problems with literacy, or have any doubts about your fitness to use mobile access towers, you should bring them to the attention of your employer. This need not preclude you from using mobile access towers, provided your employer conducts an assessment and is able to put into place adequate measures, such as, for instance a "workplace buddy", to take account of your disability).

To work at height, you need to have a "head for heights". If you don't, don't work on mobile access towers. You represent a danger to yourself and your workmates.

5.3 User's responsibilities

Always, your overriding concern has to be for your safety and the safety of anyone else who is affected by what you do.

You must always read and follow the manufacturer's instruction manual and on no account attempt to use equipment beyond its limitations. You must never use mobile access towers whilst under the influence of alcohol or drugs.

You must not misuse or abuse equipment, and you must not remove or interfere with guardrails or other devices which are provided for your safety.

6. TYPES OF MOBILE ACCESS TOWERS

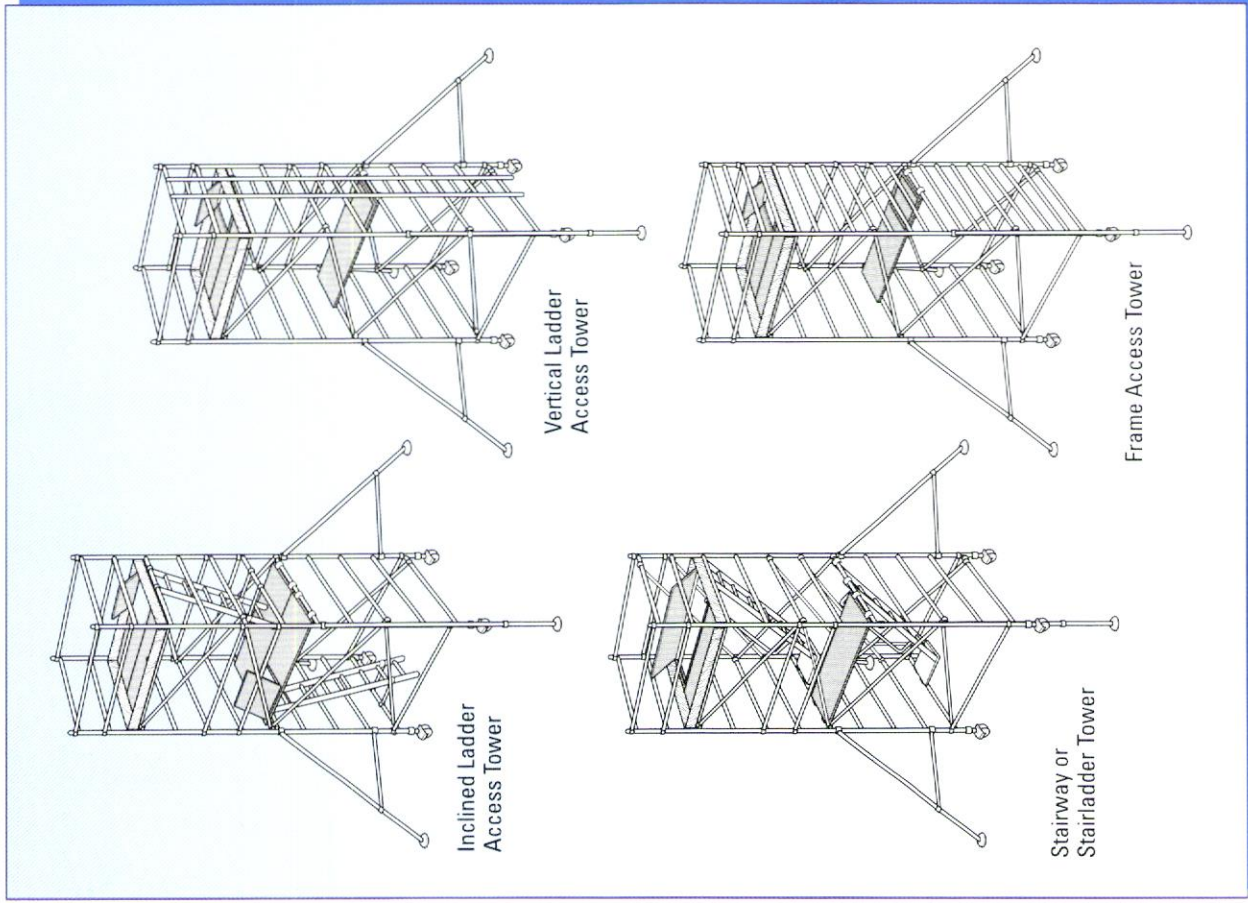

12.13 Structural Failure – Incorrect Assembly

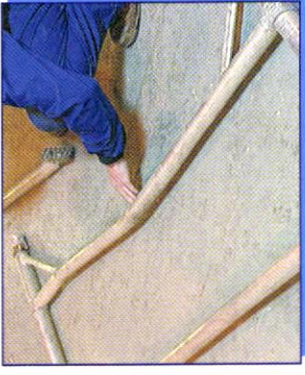

When assembling and dismantling towers, always follow the sequence explained in the manufacturers' instruction manual. Use only the right components in the right place, following the recommended bracing pattern. It is important you get this right, because this is what gives the tower its structural strength. Never remove or borrow components from an assembled tower and reject, tag and isolate damaged components.

Whilst it is an uncommon occurrence, tower structures can collapse. Investigation shows that this is almost invariably as a result of incorrect assembly, using damaged components or overloading the tower structure.

12.14 Falls from Height – Improper Use of Guardrails

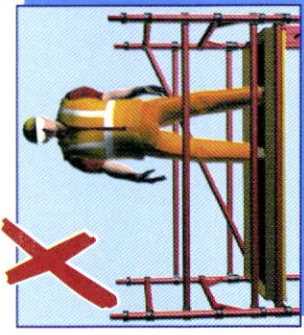

Statistics show that falls from height are historically amongst the highest causes of fatalities and serious injuries reported each year.

Guardrails are designed to prevent you falling from the platform. With the main guardrail set at about 1.0m high, which is above your centre of gravity, and the mid guardrail roughly half-way between this and the platform, so that there is no unprotected gap of more than 470mm, it is in reality quite difficult to fall.

Despite the fact that guardrails are compulsory on all platforms from which you are liable to fall 2.0m or more, some users either do not install them at all, or install them at below the correct height, so that they are below the centre of gravity of the users. All it then needs is a slip, trip or stumble and you begin to see why this accounts for such a high toll.

12.15 Falls from Height – Over-reaching

Avoid over-reaching, over-stretching or setting up a ladders, or steps, or even a box to give that little bit of extra height.

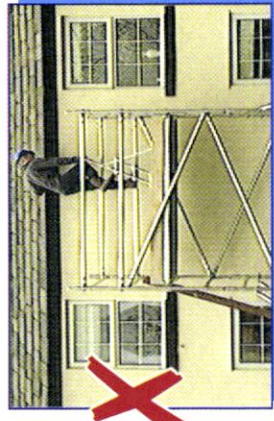

Only use additional components to increase the platform height safely.

12.8 Instability – Moving by Vehicles

Pushing, or pulling towers at the bottom, using mechanical means such as forklifts or other vehicles is strictly forbidden. Again a very dangerous practice imposing sudden side loads which could cause the tower to overturn.



12.9 Instability – Ground Conditions

Another factor that affects your tower's stability is ground conditions. If your tower is situated on soft or uneven ground or on top of grates or manholes, there is a very real possibility that it could overturn. Like any structure, it is only as good as its foundations.

12.10 Instability – Over-extension of adjustable legs

Similarly, do not over-extend adjustable legs to give you additional height, this has the effect of your tower being built on stilts, and, if you have ever tried walking on stilts, you will know just how unstable you're making your tower.

12.11 Instability – Vertical Alignment

A final factor having an obvious effect on stability, maybe so obvious that we sometimes forget about it, is vertical alignment. Put in simple terms, the levels of your tower must always be checked to ensure it is vertical.

The hazard of overturning of towers as a result of instability is most often a combination of factors. Being out of level is a common contributory factor.

A very effective way of countering many of the risks of overturning is to change your free-standing tower so that it takes its stability from an adjacent structure. PASMA recommends that all towers should be tied to an adjacent structure wherever possible. Your manufacturer's instruction manual will tell you at what point you must tie in when your tower is above the safe free-standing height for stabilisers or outriggers.

12.12 Structural Failure - Overloading

Do not exceed the manufacturers' stated maximum load, either on individual platforms or on the whole tower structure. Similarly, ensure you evenly distribute the load – don't pile all your materials, or tools, in one corner.



7. COMPONENTS

Castor – Castors are fitted with braking devices which should always be locked unless you are moving the tower. Castors come in various sizes and load capabilities. Castors should not be used on soft ground without employing sole boards.



Base Plate – Like the castor, the base plate is attached to the adjustable leg and is particularly intended for use on towers which you do not intend to move or which are sited on uneven or sloping ground.

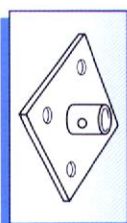

Adjustable leg – Adjustable legs are used to level the tower only. Use in conjunction with either castor or base plate. Do not use the adjustment to gain additional height.

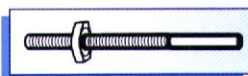

Frame – Frames provide one of the main structural elements of the tower. They come in single width accommodating one platform, and double width accommodating two platforms side by side. They are joined together by connecting spigots until the desired height of the tower is reached. The platform(s) is located on the rungs of the frame. Frames are available in various heights to ensure you can achieve the exact height you need.

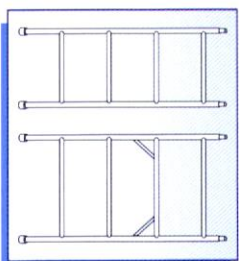

Access – Access to platforms can be provided by a number of different means. Vertical clip-in ladders, stairways and stairladders are separate components which are positioned within the tower. Integral ladder frames and frames with rungs, which are suitably spaced and non-slip, also provide a safe means of gaining access. Consult your instruction manual to determine what access is provided with your tower.

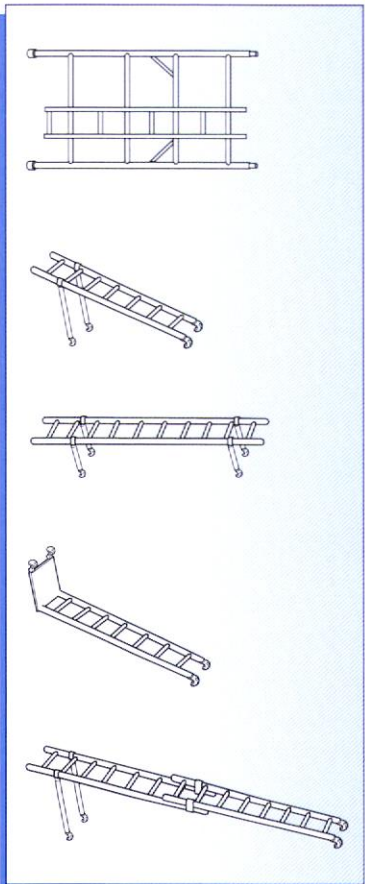

Brace – The second main structural element of the tower, braces are generally horizontal and diagonal. You can easily identify the difference between horizontal and diagonal braces, because the diagonals are always longer and the horizontals are the same length as the platform. They are usually fitted with locking hooks at each end, which are attached to the frame horizontals or verticals to make a rigid modular structure. Where braces are attached to verticals, they should always have the open side of the hook facing outwards, to prevent accidental disengagement. The manufacturer's instruction manual will clearly show the bracing pattern for each tower type.

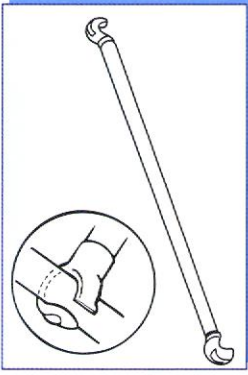

Platform – Generally comprising a frame with two hooks at each end and a slip resistant decking, platforms are designed to be safe and comfortable. They are available in various lengths and may be used singly or placed side by side to form a wider area. Platforms that hinge open are provided to allow you to access the platform from inside the tower. Trapdoor Platforms only are used on single width towers.

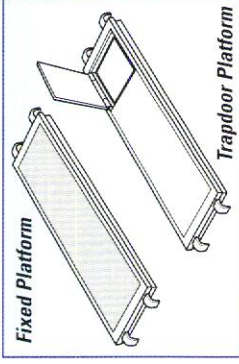

Fully Hinged Platform not shown

Toeboard – Designed to ensure tools and equipment are not dislodged from the platform area. Toeboards come in various sizes to accommodate the differing lengths and widths of towers.

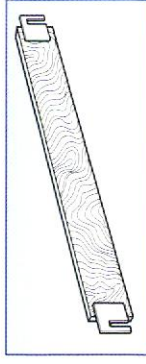

Stabilisers & Outriggers – Stabilisers and outriggers increase the effective base dimension of the tower to allow you to build higher. Stabilisers are intended for towers you intend to move infrequently, whereas outriggers, as they are fitted with adjustable legs and castors are for towers which you intend to move frequently. Outriggers require the installation of plan braces to fix them in their optimum position and prevent them folding in whilst the tower is being moved. The manufacturer's instruction manual will advise which stabilisers/outriggers are suitable for each height of tower, their positioning and sequence, although as a general rule they should be fitted at the earliest opportunity.

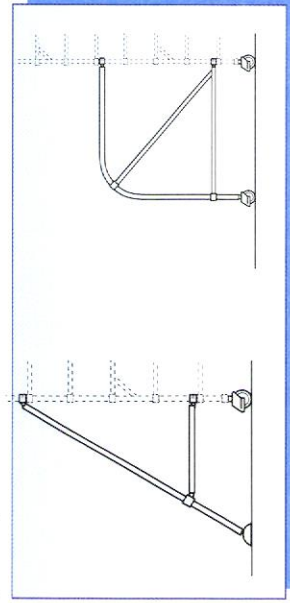

A factor that makes the effect of wind even more dangerous is the attachment of sheets or tarpaulins to towers, or working with sheet materials such as cladding. These act like sails and, even in relatively light winds, can still cause the tower to overturn. Such towers must be tied in at all times and the advice of the supplier should be sought.

Be cautious about the use of towers in open ended buildings, such as hangars or unclad buildings, as the wind forces in such locations can often be greater than if the towers are used outside the building, due to the funnelling effect of the wind.

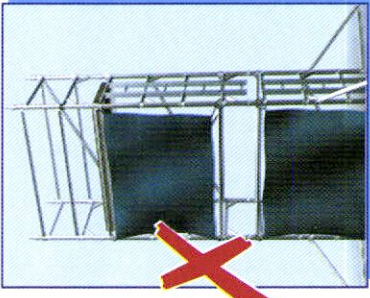

12.6 Instability – Side Loads

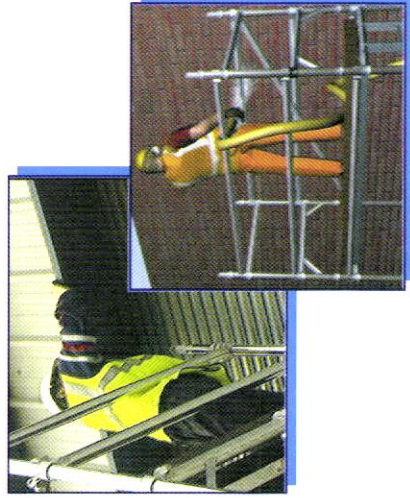

As well as the effects of wind, another example of a side load is where the tower is pushed or pulled, particularly at the top. Pushing or pulling a tower at platform level is very dangerous and could cause the tower to overturn. Side loads at the platform can also be caused by such things as shotblasting, high pressure jets, percussion drills and even the effects of pulling loads up the outside of the tower. This list is not exhaustive, there may be other things in your work that could apply side loads. The maximum allowable side load at the platform is 20kg.

12.7 Instability – Vertical Loads

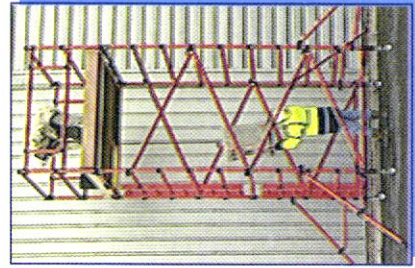

Any vertical load outside the area of the tower can be hazardous. For example, heavy materials hoisted outside the effective base area of the tower have a tendency to overturn the tower particularly if no outriggers or stabilisers are fitted as can be the case with towers of lower height.

Loads must be hoisted within the EFFECTIVE BASE AREA of the tower (i.e. within the area bounded by the tower or stabilisers/outriggers where fitted.) Your instruction manual must be consulted about hoisting loads to ensure safe and stable use of the tower.

12.3 Striking by Vehicles

If you are working on a tower structure which is sited at, or near, a road, you must take appropriate steps to ensure vehicles cannot come into contact with the tower. Use cones or barriers, or you may even in some cases have to arrange traffic diversions. This does not only apply to public highways. Give the same consideration when you are working in a factory or a site, where forklift trucks, delivery vehicles and such like can cause the same problems. Remember this is a temporary structure. Drivers and forklift operators do not expect the tower to be there. In fact, they may not even notice it, until it's too late.



12.4 Falling Objects

The hazard of falling objects consists of two categories. Objects can fall because they are dropped intentionally, perhaps because you are in a hurry to get the job done. The momentum, which can gather with even lightweight components, makes such a practice extremely dangerous for anyone in the vicinity and is therefore not permitted in any circumstances.

Of course objects such as tools or materials can fall from the platform unintentionally. Toeboards are designed to prevent exactly such an occurrence and are provided with every tower supplied by a PASMA member and regulations say you must fit them to working platforms or to platforms where you intend to store tools or materials.



12.5 Instability – Effects of Wind

A major factor affecting stability is the effect of wind. But, determining wind speeds can sometimes present difficulties. You could use a hand-held wind speed device, an anemometer. Wind imposes a horizontal load on the tower tending to overturn it. In normal safe working conditions this tendency to overturn is counteracted by the selfweight of the tower, and the stabilising effect of the outriggers or stabilisers.

The current standard requires that towers must be stable in a freestanding condition in a wind speed that equates to 28 mph or Beaufort force 6. If the wind speed should exceed 17mph you should cease to work upon the tower. If the wind speed is likely to reach 25mph the tower should be tied into a rigid structure, and if it is likely to reach 40mph, the tower should be dismantled.

8. ASSEMBLING THE TOWER

8.1 Instruction Manuals

All PASMA members supply comprehensive instruction manuals on the erection and dismantling of towers which will comply with the current standard. Suppliers and users should ensure that these manuals are available to the operatives erecting and using the tower, and to the person supervising the work.

Employers should also ensure that the operatives erecting the tower are competent to do so by training (or are closely supervised by such a person) PASMA have designed a recognised certification system for this purpose.

8.2 Type & Number of Components

The type of components used for the construction of a tower must be compatible. Not only should they all be components from the same supplier, they should also be those recommended for the particular tower configuration.

Suppliers usually provide a range of different types of towers and although some components are interchangeable between types, this is not always the case and unsuitable components should be rejected. Before commencing to erect the tower make sure that the correct number of components are available by laying out and counting all the components and comparing them to the table in the instruction manual and the supplier's delivery note. Never attempt to make up deficiencies by the use of alternative suppliers' parts or random scaffold tubes, couplers or scaffold boards and such like.



8.3 Suitability of Site – Ground Conditions

Towers should be erected and used only on ground suitable for the purpose, e.g. concrete, tarmac or similar. Where towers are on soft or uneven ground, base plates should be used instead of castors, and these should be set on sole boards or other decking which will provide a firm foundation. Outriggers and stabilisers should be similarly treated.



8.4 Castors, Base Plates & Adjustable Legs

Begin assembly by fitting either castors or baseplates to four adjustable legs. The design includes a feature to prevent the castor or base plate from falling out of the adjustable leg. The adjustable legs are fitted into the lower ends of the verticals of two frames. A retaining mechanism on the adjustable leg prevents it from detaching from the frame. Each leg has a device to vary its extension, so that the tower can be made level on uneven or stepped surfaces. This is NOT a means of gaining additional height and the extension of the adjustable leg should be the minimum possible. Where adjustment is required beyond that for normal levelling purposes, consideration should be given to the use of offset (or stepped) for which the supplier's advice must be sought.

8.5 Base Module

The base module, comprising the two frames and braces, is then assembled according to the supplier's instructions. The legs should then be adjusted so that the base module is vertical and the two end frames are at the same level.

PASMA recommends that the tower be checked using a spirit level vertically, across the width and across the length to ensure it is level. It is sensible that the tower be assembled

in the position in which it is to be first used, otherwise the tower may have to be re-leveled when it is moved into the working position. If castors are used, these should now be braked. For tiered floor situations the frames can be at offset levels as recommended by the supplier. Generally these offset frames will require extra diagonal bracing which should be placed in the positions the supplier recommends. If stabilisers or outriggers are required you should generally be fixing them at this stage, but refer to your instruction manual to be certain, (*refer to 8.11 Stability*).

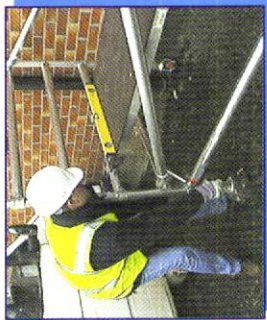
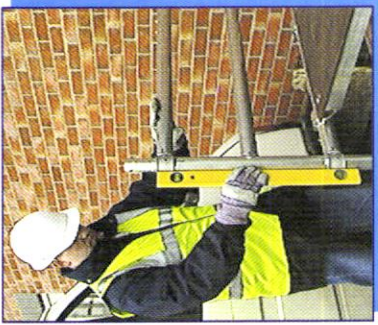

8.6 Upper Modules

The upper sections of the tower can now be erected following the sequence in the supplier's manual. Frames are usually connected by a spigot and socket joint with a locking mechanism which you must ensure is positively engaged and locked. All other tower components must be fitted in the correct positional sequence and following the manufacturer's recommended bracing pattern – without omissions. Take particular care to follow the manufacturer's instructions to ensure you are protected from falling in the course of assembly and check the instructions for the manufacturer's recommended methods for lifting components.

8.7 Braces

Diagonal and horizontal (handrail) braces have locking hook mechanisms which engage with either horizontal or vertical frame members. When fitted to horizontal members locking hooks must have their aperture facing downwards. When horizontal braces are fitted to

verticals ensure that locking hooks have their aperture facing outboard. In all cases when fitting braces ensure that the hook mechanisms have operated correctly, the brace is securely fixed to the frame, and the hooks are located correctly on both sides.

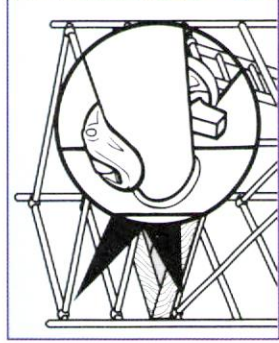
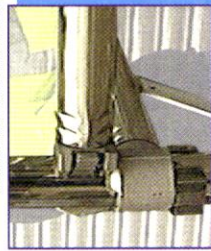

11. DISMANTLING THE TOWER

Follow the manufacturer's instruction manual for dismantling and ensure that components are removed in the correct sequence. Take particular care to follow the manufacturer's instructions to ensure you are protected from falling in the course of dismantle and check the instructions for the manufacturer's recommended methods for lowering components. Remember site conditions may have changed since you assembled the tower.

12. HAZARDS

12.1 Slips

You can avoid slips by not working on towers in snowy or frosty weather or in heavy rain. Similarly, you will also avoid slips by climbing only on those parts of the tower which are designed for climbing – either on the ladder section or on the special anti-slip rungs on some towers.



12.2 Electrocution

The hazard of electrocution can be avoided by staying clear of overhead electrical cables. Aluminium towers certainly aren't insulated, although fibreglass towers do provide considerable insulation properties. For details of the insulation properties, contact your supplier.



If you need to work in the vicinity of overhead electrical cables, consult HSE Guidance Note and your local power company for advice on safe distances. Be aware of the flash factor, (arcing), particularly in wet conditions.

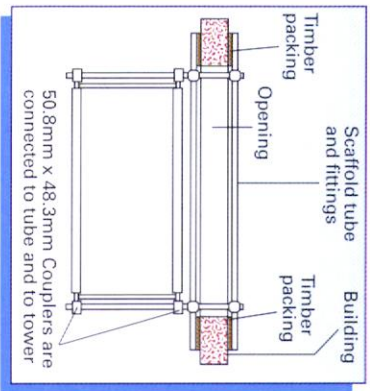

Through Tie

You **should** tie in towers of all heights wherever possible, as it is safe practice to do so. However, where towers are left unattended or are to be located in particularly exposed conditions, wind forces will almost certainly affect stability. In these circumstances ensure that the tower is adequately tied in or restrained from blowing over and that the platforms are securely fixed, or alternatively the tower dismantled.

10.1 Ballast Weights, Guy Ropes and Ground Anchors

Where additional stability is required, but cannot be achieved by tying into a rigid structure then it is possible to obtain stability by the use of ballast weights, guy ropes or ground anchors. Ballast must be of solid materials (i.e. not sand, water or other liquid or granular materials) and must be securely attached to the tower structure.

Ballast weights placed on to the base of the structure will increase tower self-weight, thereby increasing stability. Your supplier or other competent person should specify the correct amount of ballast weight and care should be taken to see that the total safe load on the structure, and particularly on the castors, is not exceeded.

It is inadvisable to use guy ropes for stability unless under specialist direction. The tower can be secured to the ground by ground anchors, anchor bolts or spikes. Anchors should be of adequate strength and the method of attachment to the tower must be as specified by the supplier because of the extra loading on the tower.



Hilti Ring



Fischer Tie

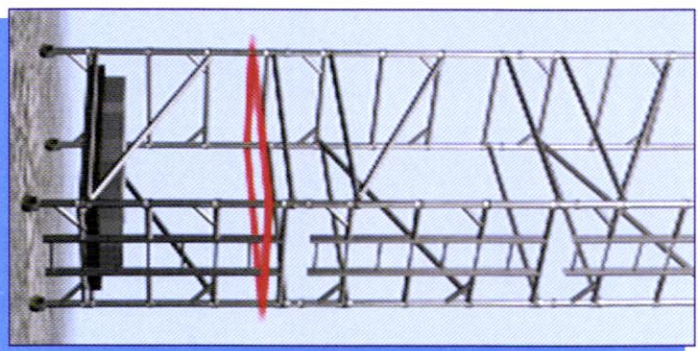

8.8 Platforms

All platform units have hooks at each end which locate onto the horizontal members of frames. Ensure that these are properly positioned and that the platform sits firmly and squarely in place. If platforms have a full access deck ensure that the hinge is outboard. The windlock device(s) on the platforms should be engaged. In accordance with the product standard, platforms must be installed at least every 4 metres in height although PASMA recommend the use of an extra platform and handrails to assist in the assembly of towers.

8.9 Guardrails and Toeboards

All platforms from which anyone is liable to fall 2.0m or more must be fitted with guardrails. Care should be taken to see that these are correctly fitted in accordance with the supplier's instructions. The diagram below shows the dimensions for guardrails and toeboards to comply with the current product standard.

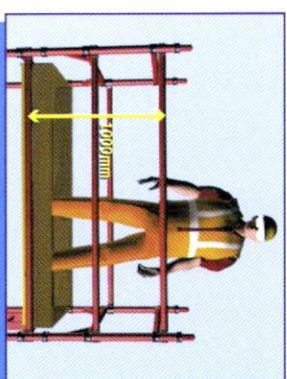

+/- 50 mm (Minimum 950 mm)

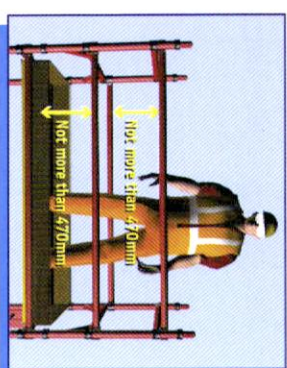

In order to protect users from the risk of falling through an unprotected gap, current regulations require that an intermediate guardrail, or some other suitable barrier, must be installed.

Whilst the provision of guardrails on towers from which anyone is liable to fall 2.0m or more is compulsory, risk assessment may indicate the need for such fall protection at lower heights.

Toeboards are mandatory on all working platforms from which tools or equipment are liable to fall 2.0m or more. Their use on intermediate, or rest, platforms is not compulsory unless a risk assessment identifies a risk that items such as tools and/or materials may be stored there and may fall from the unprotected platform.

8.10 Method of Access

Access to the platform must be provided by vertical clip-in ladders, integral ladder frames, suitable frame access incorporating non-slip rungs, stairladders, inclined ladders or stairways. These should be erected as shown in the supplier's instructions. If materials are to be carried or frequent vertical movement required, a stairway should be used.

EXTERNAL LADDERS MUST NEVER BE USED WITH MOBILE ACCESS TOWERS.

Access to or through a platform must be via a trap door which must be capable of being secured in the closed position.

8.11 Stability

The major reason for selecting mobile access towers to provide access is the lightness of the components and the consequent ease of assembly compared to the heavier sections of steel scaffold structures. In mobile form, aluminium towers are easy to move from point to point, but the lightness of the structure means that care has to be taken to ensure the stability of the tower.

It is no longer appropriate to apply simple rules of thumb (e.g. measure 3 x minimum base dimension for external use) but instead the manual the supplier provides will show the safe height to which various tower configurations can be erected, and will give information on the use of stabilisers and outriggers to increase the stability of high towers. If these instructions are observed, aluminium alloy towers provide a stable and firm work platform for a wide variety of applications. PASMA recommends that stabilisers or outriggers are added at the first available opportunity, usually after the first module is complete.

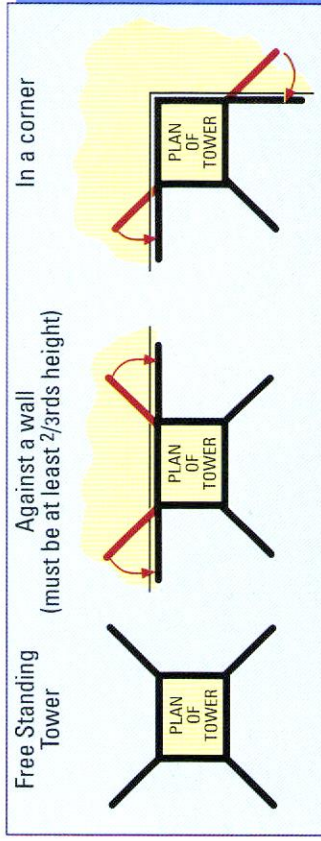

The illustration shows the optimum positions for stabilisers and outriggers.

PASMA Manufacturers' towers all comply with British and European standards. This is your guarantee that, amongst other things, your tower meets very strict requirements for stability and meets stringent quality control criteria.

9. MOVING THE TOWER

Towers should be moved with the utmost caution. Before moving, check the suitability of the intended route to ensure there are no obstructions, both at ground level and overhead. (particularly overhead cables). Men and materials must be removed and the height of the tower reduced to 4.0m. Finally, the stabilisers should be left in position and raised no more than 25mm from the ground. The tower must only be moved by applying manual force at or near the base of the tower and you should ensure you have sufficient operatives on hand to control the movement of the structure.

PASMA do not recommend that assembled towers be suspended, for instance, by a crane. The manufacturer must approve any intended use of this nature and provide an appropriate design and method statement.

PASMA recommends outriggers in preference to stabilisers if a tower is to be moved frequently.

ENSURE ANY HOLES, DUCTS, PITS OR GRATINGS ARE SECURELY COVERED BEFORE MOVING YOUR TOWER.

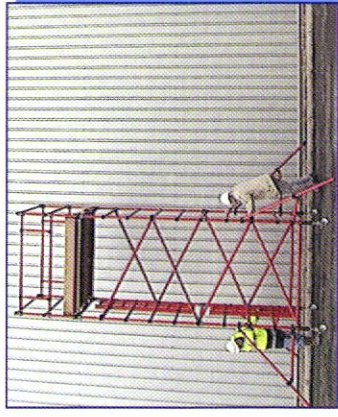

Diagram showing tower being moved, clearance of 25mm on stabilisers and maximum platform height when moving of 4.0m.

10. TYING IN THE TOWER

Mobile access towers are supplied as free-standing units for heights to the working platform of 12m. and some suppliers provide special towers that are free standing up to 16m. Towers above these heights or where the optimum base dimensions cannot be constructed must be rigidly tied into an adjacent structure and the advice of the supplier should be sought.

Tying-in is normally achieved with aluminium or steel tubes and compatible couplers, but, as most PASMA towers have tubes of larger diameter (50.8mm) than standard scaffold tube (48.3mm), standard scaffold couplers are not suitable for coupling PASMA towers. If steel or aluminium scaffold tubes are connected to tower structures, the user should ensure that the coupler used is suitable, i.e. one that will accept the two different sizes of tube. These are available from PASMA members.